

Automation
Simplified...

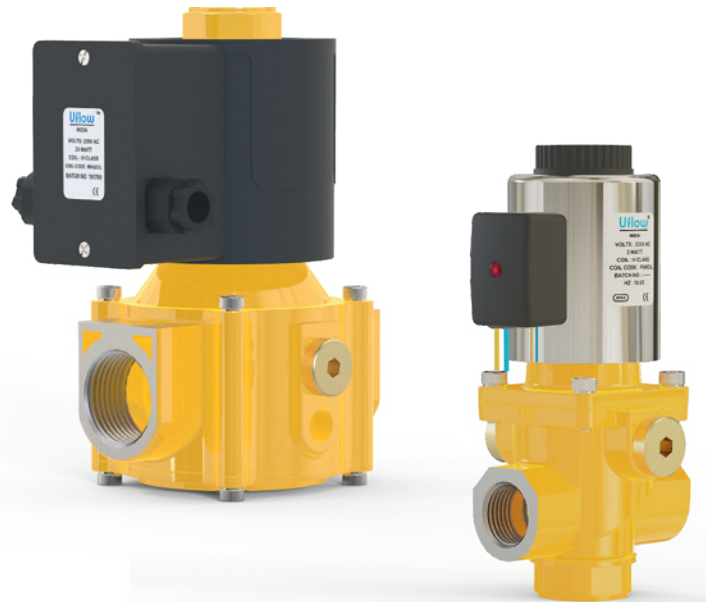

Solenoid Valve

Angle Seat Valve

Rotary Coupling

Pneumatic Directional Control Valve

Actuator

Cylinder

One Touch Fitting

Ball Valve

Butterfly Valve

Country of Origin - INDIA



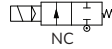
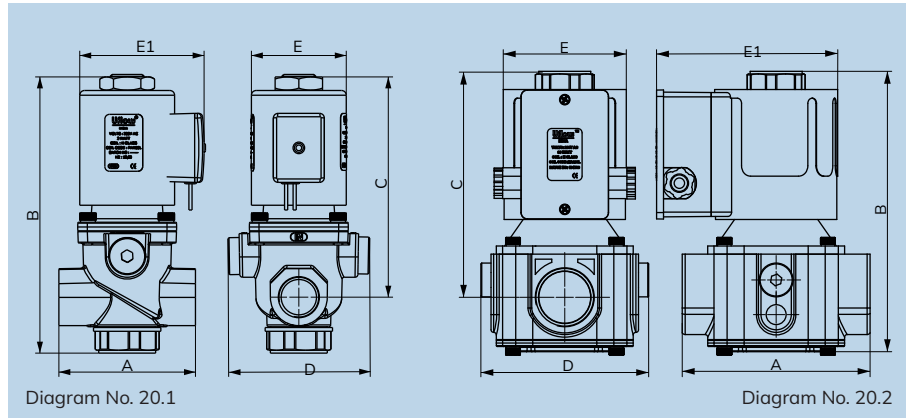

Specifications

Port :	Refer below technical data sheet (Available BSP)	
End Connection :	Screwed	
Body Material :	Aluminum Pressure Die Cast	
Diaphragm :	Nitrile (NBR)	
Media Temp :	-30°C to 90°C	
Circumstance Temp :	-10°C to 70°C	
Media :	Air, Natural Gas, Town Gas	
Main Features :	Flow adjustment, Opening time adjustment, Quick release initial flow adjustment	
Operating Voltage :	110AC	230AC
Power Consumption :	30W	30W
Coil Features :	High Reliability Unaffected by Voltage Surges. Easy coil changes coil lockable in 4X90 position or freely movable in between as require.	
Coil Housing :	Epoxy square coil.	
Other Specification Data :	Available on Request	

NOTE: Use of filter in the inlet port is recommended.

- Coils are conforming as per IEC-60335-1 with derivatives (LVD / EMC).
- Gas Solenoid Valve complies as per EN-161 requirement.

Dimension (All dimensions are in mm)

All Dimensions are approx.

Model No.	Port Size	Diagram No.	A	B	C	D	E	E1
DAN201BNIW152V0	½"	20.1	72	147	116	75	50	66
DAN400BNKW300V0	1"	20.2	108	162	130	97	71	105

Section View

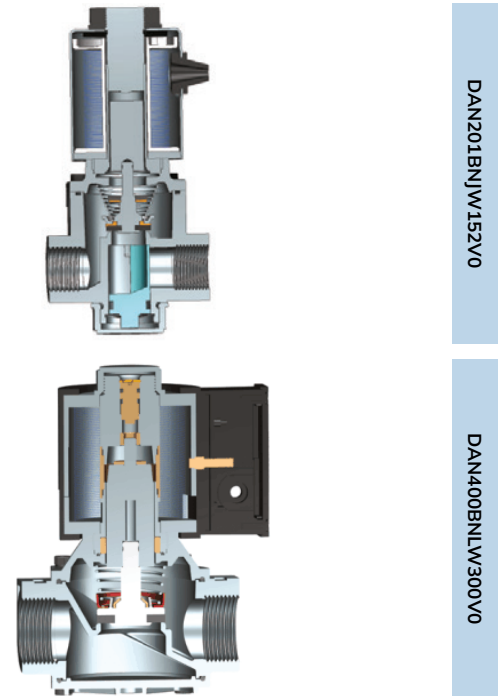

Technical Data

Model No.	Body Material	Pipe (Inch)	Orifice (mm)	Min. Operating Pressure mbar	Max. Operating Pressure mbar	Seal & Diaphragm Material	Flow Factor Kv m³ / hr
DAN201BNIW152V0	Aluminium	½"	15	0	500	NBR	4
DAN400BNKW300V0	Aluminium	1"	30	0	300	NBR	13

NOTE: Please refer the direct acting model identification chart.

DIRECT ACTING SOLENOID VALVE MODEL IDENTIFICATION CHART

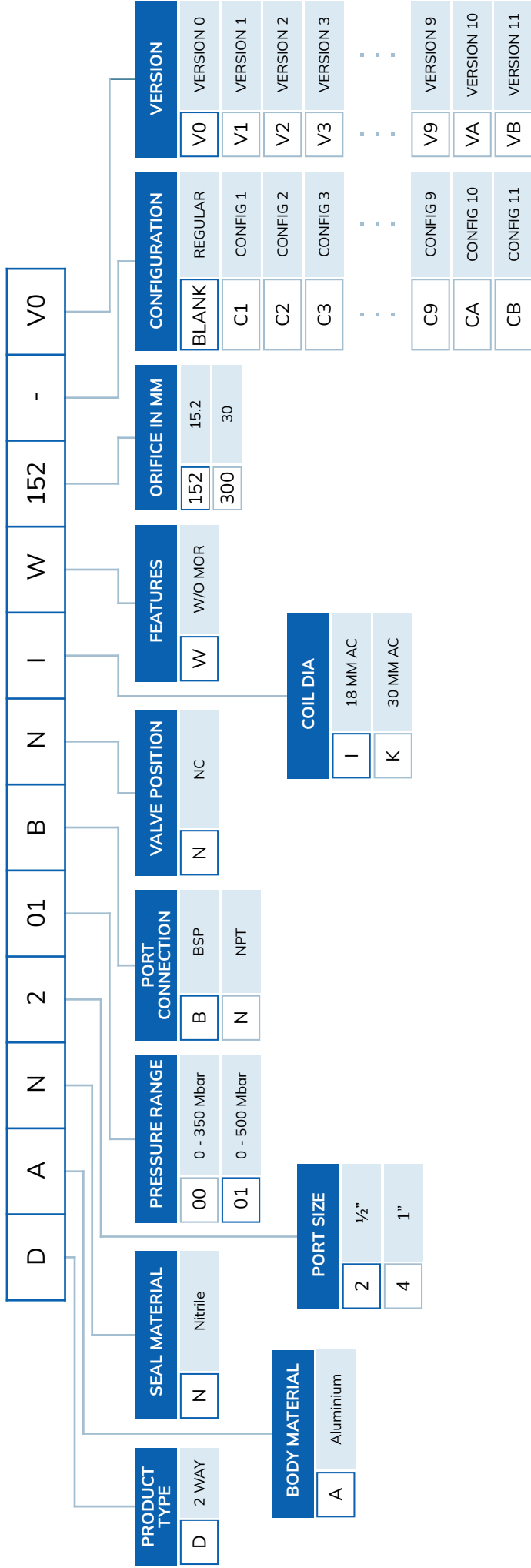

DAN201BNIW152V0

1/4" 2 WAY DIRECT ACTING ALUMINIUM-NITRILE-0 TO 500MBAR-BSP-NC-18mm AC-MOR-15.2mm ORIFICE

Global Presence...



Made In India



CONTACT US:

✉ sales@uflowvalve.com ☎ +91 89059 07070 📞 +91-2827-254343 🌐 www.uflowvalve.com

📍 Uflow Automation, Ankur Industrial Complex, Sur vey No: 275/276, Plot No: 31, Nr. Intol Cast Pvt. Ltd. Shapar(Veraval) Dist.: Gujarat (India) - 360 024.